

CUSTOM 15000

PB-C15K 1.0.01

ClimateMachines™ CUSTOM 15000 is a built-on-site air handling unit available in three standard set-ups: Low, Medium and High. These models are adaptable and can be custom built to accommodate for pillars, beams or sloped ceilings.

The use of high-quality materials allows employment of a special pressure setup with pushing supply fans and pulling extract fans. This guarantees 0% contamination between supply air and extract air*. Combined with a low airflow through the heat exchanger this leads to high performance with 90% thermal efficiency.

The indirect evaporative cooling system provides a high cooling capacity which significantly reduces or even eliminates the need for additional cooling units or district cooling.

* Verified by RISE, <https://www.ri.se/en>

Thermal Efficiency Comparison

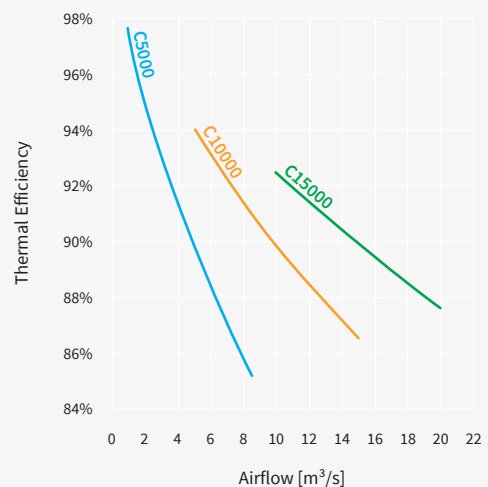

Performance

Winter Conditions Heat recovery

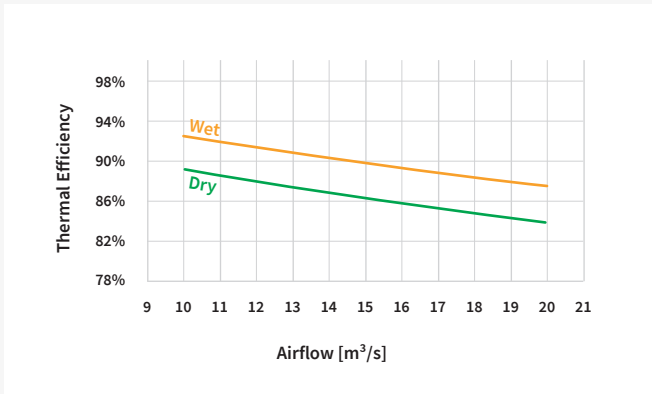

Summer Conditions Evaporative cooling

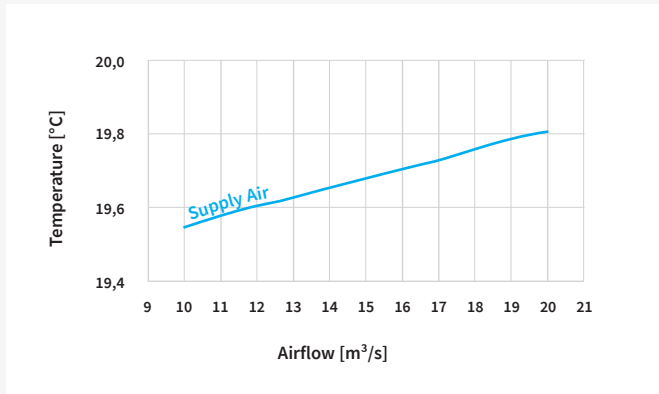

Dimensioning Conditions Winter

Wet			
	T [°C]	RH [%]	Airflow [m³/s]
Outdoor Air	-20	80	10,0 - 20,0
Extract Air	22	30	10,0 - 20,0
Dry			
	T [°C]	RH [%]	Airflow [m³/s]
Outdoor Air	5	80	10,0 - 20,0
Extract Air	25	27	10,0 - 20,0

Dimensioning Conditions Summer

	T [°C]	RH [%]	Airflow [m³/s]
Outdoor Air	27	50	10,0 - 20,0
Extract Air	23	60	10,0 - 20,0

Control & Monitoring System

ControlMachines™ is a control, monitoring and data collection system that meets modern demands on user-friendliness, accessibility and security.

ControlMachines™ is developed with the user experience in focus, for real-time monitoring and analysis of energy installations and facilities. The control system visualises performance and enables easy optimisation of facility operations.

The client software is web-based which provides you with a straightforward solution for remote control and monitoring of your facilities. All devices connected to the Internet with modern web browsers can access ControlMachines™.



Connections

Ventilation

Connection	Dimension	Type
Exhaust Air	Project dependent	Flange
Outdoor Air	Project dependent	Flange
Supply Air	Project dependent	Flange
Extract Air	Project dependent	Flange

Plumbing

Connection	Dimension	Type
Evaporative Cooling	DN20	PP
Waste Water	DN50	PP
Coil Heat Exchanger	Project dependent	Project dependent

Electricity

Supply Voltage	3~400 VAC
Power Rating	Project dependent
Ampacity	Project dependent
Inrush Current	Project dependent
Overcurrent Protection	Project dependent

Dimensions

Custom 15000 is available in three standard set-ups: Low, Medium and High. These are adaptable and can be mirrored or custom built to accommodate for pillars, beams or sloped ceilings. For more information, please contact us.

Low

🏗️ Weight: 12500 - 16000 kg

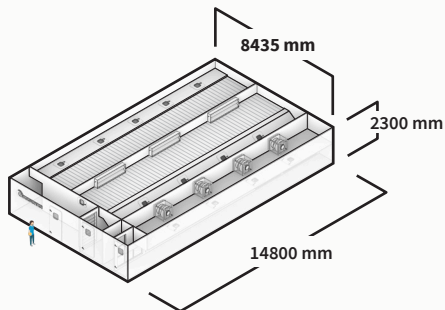

Medium

🏗️ Weight: 11700 - 14700 kg

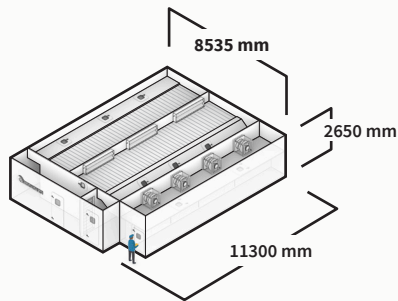

High

🏗️ Weight: 11200 - 13700 kg

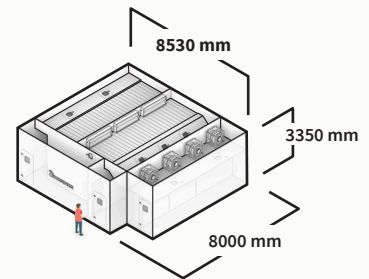

List of Components

Standard

Component	Type	Model
Crossflow Heat Exchanger	Polycarbonate, Two-step	15000
Unit Casing	Sandwich 50 mm	EPS
Fans SF/EF (4+4)	EC Centrifugal Fan	-
Supply Air Filter	Compact Filter F7	-
Bypass Damper SA/Ext. A	Comfort Damper	Leakage Class 4
Control System	ControlMachines	Logic
Monitoring System	ControlMachines	Scada

Optional

Component	Type	Model
Fire Resistant Unit Casing	Sandwich (EI30 or EI60)	Mineral Wool
Extract Air Filter	Compact Filter M6	-
Fan Shut-off Dampers	Comfort Damper	Leakage Class 4
Panel	23" Touch Screen	-
Finned Coil Heat Exchanger	Project dependent	-
Service Lighting	LED	-

Additional options

Indirect Evaporative Cooling	Efficient cooling that cuts peak power consumption using only water
Video Monitoring	Remote visual confirmation of operation (e.g. bypass dampers)
Outdoor Adaptation	For outdoor installations
Color Shifting LED	Indicates operating conditions and performance
Lockable Doors	For placement in publicly accessible areas
Energy System Support	Service agreement, including performance reports

